

B

MAGNETIC POSITION DETECTOR



Reed-switch type or magneto-resistive type (MR)
Installation into the T-slot grooves (see page P291)

T-SLOT GROOVES



Grooves in 3 sides

EASY MOUNTING

Wide choice of standard mountings and rod ends

STURDY DESIGN

Rod in hard chrome steel tapped or threaded

PRECISE ROD GUIDANCE

With high-performance self-lubricating bearing and non-abrasive scraper seal

EASY MAINTENANCE

Series 449 cylinders do not require lubrication.

ESTHETIC DESIGN

Cylinders with profiled barrel in hard anodised aluminium

STANDARD SWIVEL TRUNNION MOUNT



As a fastening option, this trunnion slides on the barrel for on-site positioning.

STANDARD MOUNTINGS (see page P226-5)

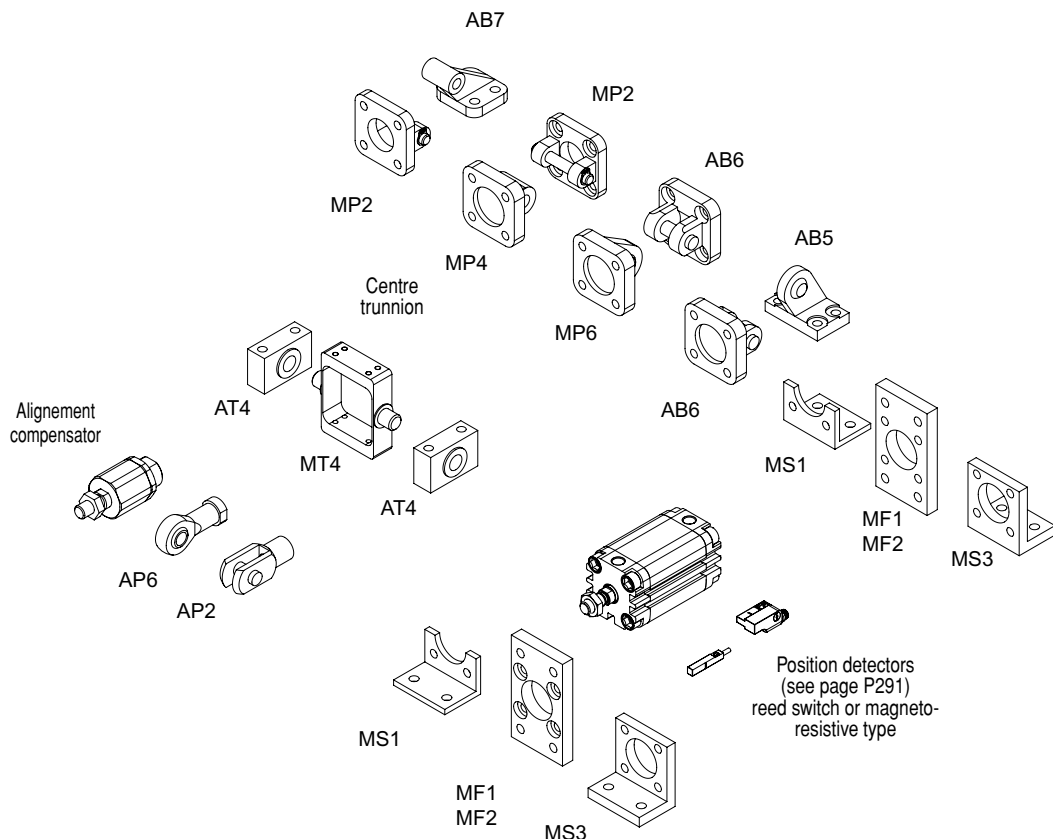

01411GB-2012/R01
Availability, design and specifications are subject to change without notice. All rights reserved.

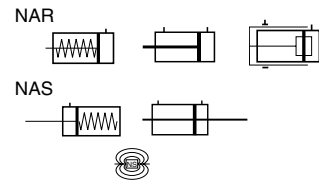

GENERAL

Detection
Fluid
Operating pressure
Ambient temperature
Max. speed rate
Standards

Equipped for magnetic position detectors
Air or inert gas, filtered, lubricated or not
10 bar, max. [1 bar = 100 kPa]
-20°C to +70°C (for higher temperature, see HTP option)
0,5 m/s
ISO 21287

Minimum pressure to compress the spring (NAR and NAS)

Ø20-50 = 1 bar
Ø63-100 = 0,65 bar

The return of the piston rod must be without load (single acting version)

CONSTRUCTION

Barrel	Hard anodized aluminium alloy
Front and rear ends	Aluminium alloy
Bearing	Self-lubricating metal
Rod	Ø 20-25: stainless steel Ø 32-100: Hard chrome plated steel
Rod end	Tapped or threaded
Piston	POM (polyacetal) or light alloy
Piston seals	PUR (polyurethane)
Version with antirotation device	Load carrying plate Aluminium alloy Guide rod Ø 20-25: stainless steel Ø 32-100: Hard chrome plated steel Bearing guide rod Self-lubricating metal



15-DIGIT PRODUCT CODE

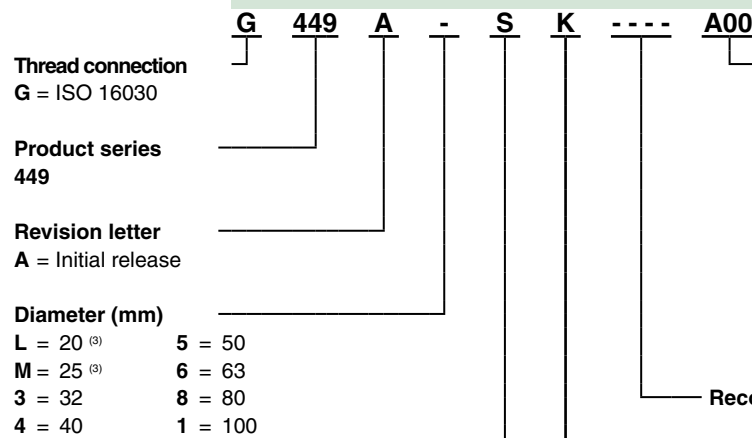

Options

- A00** = Without
 - MT4** = Non fixed centre trunnion (MT4 axis perpendicular to the ports)⁽¹⁾
 - MS4** = Non fixed centre trunnion (MT4 axis parallel to the ports)⁽¹⁾
 - AT1** = ATEX zones 1/21
 - AT2** = ATEX zones 2/22
 - HTP** = High temperature (up to 120°C)⁽²⁾
 - NPC** = Anticorrosion treatment on covers & high-quality rod seals
- ⁽¹⁾ For fixed supplied centre trunnion, consult our Dynamic Product Modeling Tool on www.asconumatics.eu and indicate XV dimension.
⁽²⁾ Non equipped for magnetic position detectors

Recommended standard strokes (mm) ⁽⁵⁾

Ø mm	connect. Ø (G)	5	10	15	20	25	50	80	100	max. stroke	Rod antirotation device max. stroke
20	M5	SD	SD	SD	D	D	D			60	60
25		SD	SD	SD	SD	D	D			60	60
32		SD	SD	SD	SD	SD	D	D		400	100
40	G1/8	SD	SD	SD	SD	SD	D	D	D	400	100
50		SD	SD	SD	SD	SD	D	D	D	400	100
60		SD	SD	SD	SD	SD	D	D	D	400	100
80		SD	SD	SD	SD	SD	D	D	D	400	100
100		SD	SD	SD	SD	SD	D	D	D	400	100

⁽⁵⁾ Other strokes on request. / Min. stroke: 5 mm
D = Double acting only / SD = Single & Double acting

Rod options 1

- S** = Double acting
- 1** = Single acting rod in
- 2** = Through rod
- 3** = Single acting rod out
- 4** = Rod antirotation device

Rod options 2 ⁽⁴⁾

- K** = Hard chromed female thread rod end
 - M** = Hard chromed male thread rod end + rod nut
 - G** = Stainless steel female thread rod end
 - N** = Stainless steel male thread rod end + rod nut
- ⁽⁴⁾ K and M = No use with the 20/25 mm diameters.

POSITION DETECTORS

Magnetic position detectors must be ordered separately: modèles "T" (see page P291), reed switch or magneto-resistive type

MOUNTINGS

Mountings must be ordered separately: see page P226-5

INSTALLATION

- For a longer lifetime, it is recommended to use external stoppers

DIMENSIONS (mm), WEIGHT (kg) 



SINGLE-ROD TYPE CYLINDER Ø 20-25

Bare cylinder
ISO 21287

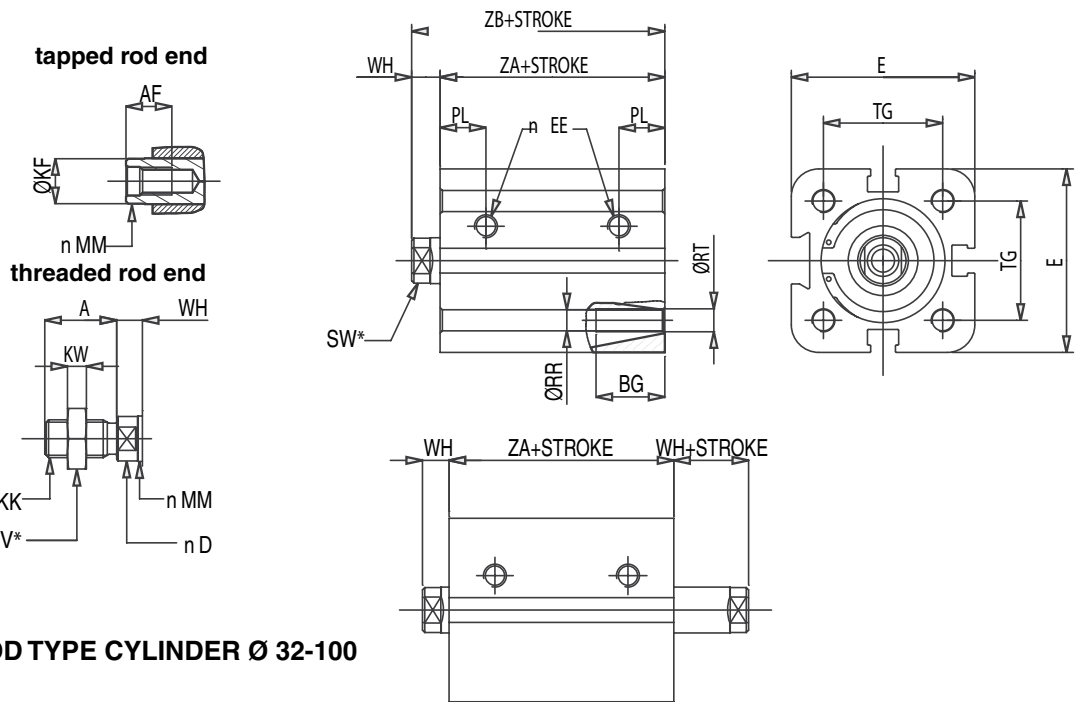

SINGLE-ROD TYPE CYLINDER Ø 32-100

Bare cylinder
ISO 21287

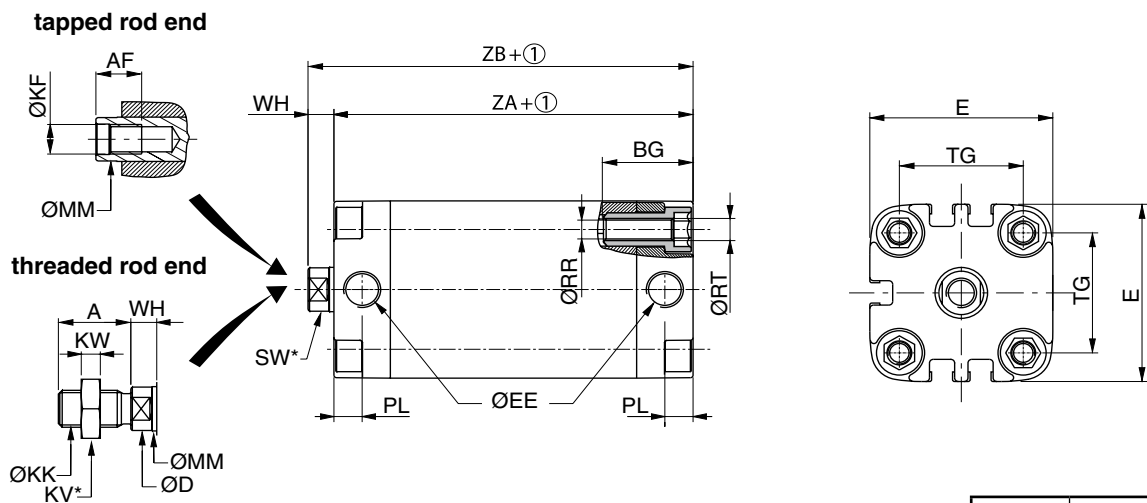

THROUGH-ROD TYPE CYLINDER

Bare cylinder
ISO 21287

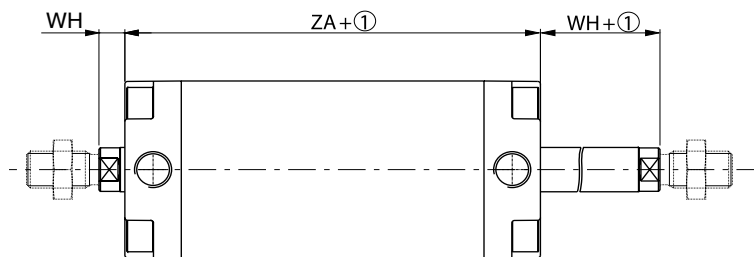

① Stroke

* Width across flats

Ø	weight	
	(2)	(3)
20	0,125	0,0026
25	0,15	0,003
32	0,228	0,0029
40	0,282	0,0033
50	0,421	0,0048
63	0,553	0,0053
80	0,991	0,0078
100	1,818	0,0099

(2) Cylinder weight at 0 mm stroke.

(3) Weight to be added per additional mm length.

Ø	A	AF	BG	ØD	E	EE	ØKF	ØKK	KV	KW	ØMM	PL	ØRR	ØRT	SW	TG	WH	ZA	ZB
20	16	10	15	9,8	36	M5	M6	M8x1,25	13	4	10	10	4,5	M5	8	22	6	37	43
25	16	10	15	9,8	40	M5	M6	M8x1,25	13	4	10	10	4,5	M5	8	26	6	39	45
32	19	12	23,5	11,8	48	G 1/8	M8	M10x1,25	16	5	12	7,5	5,1	M6	10	32,5	7	44	51
40	19	12	23,5	11,8	54	G 1/8	M8	M10x1,25	16	5	12	7,5	5,1	M6	10	38	7	45	52
50	22	16	27,5	15,8	66	G 1/8	M10	M12x1,25	18	6	16	7,5	6,7	M8	13	46,5	8	45	53
63	22	16	27,5	15,8	78	G 1/8	M10	M12x1,25	18	6	16	7,5	6,7	M8	13	56,5	8	49	57
80	28	20	28,5	19,8	96	G 1/8	M12	M16x1,50	24	8	20	8,5	8,5	M10	16	72	10	54	64
100	28	20	28,5	24,8	115	G 1/8	M12	M16x1,50	24	8	25	10	8,5	M10	21	89	10	67	77

01411GB-2012/R03 Availability, design and specifications are subject to change without notice. All rights reserved.

B

MAX. ADMISSIBLE LOAD "F" ON THE ROD END

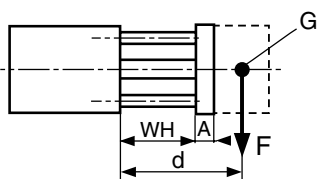

d = the projection distance (in mm) corresponds to the dimensions WH + A + the stroke length + the distance from the centre of gravity (G) of the load to the front mating surface of the load carrying plate.

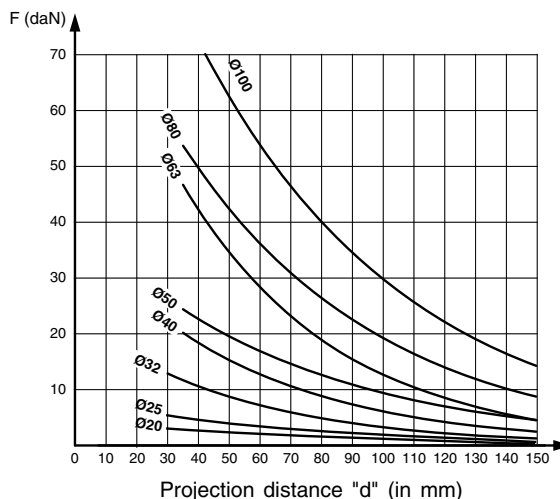

DIMENSIONS (mm), WEIGHT (kg)



CYLINDER WITH ANTIROTATION DEVICE

Bare cylinder
ISO 21287

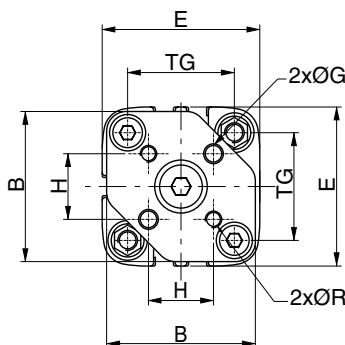
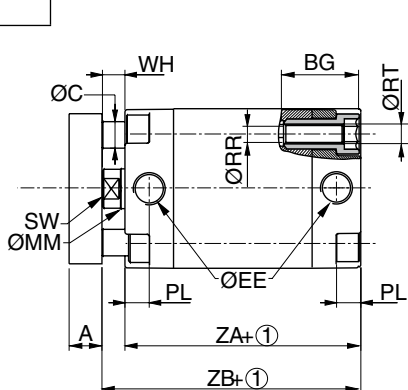

Ø	weight	
	(3)	(4)
20	0,150	0,0029
25	0,1901	0,0034
32	0,328	0,0037
40	0,392	0,0041
50	0,601	0,0061
63	0,773	0,0065
80	1,381	0,0096
100	2,348	0,0116

(3) Cylinder weight at 0 mm stroke.
(4) Weight to be added per additional mm length.

- ① Stroke
- ② Mounting holes (see page P226-3)

Ø	A	B	BG	ØC	E	EE	ØG	H	ØMM	PL	ØR	ØRT	ØRR	SW	TG	WH	ZA	ZB
20	8	30,5	15	5	36	M5	4	12	10	10	M4	M5	4,5	8	22	6	37	43
25	8	36,5	15	6	40	M5	5	15,6	10	10	M5	M5	4,5	8	26	6	39	45
32	10	45,3	23,5	8	48	G1/8	5	19,8	12	7,5	M5	M6	5,1	10	32,5	7	44	51
40	10	51	23,5	8	54	G1/8	5	23,3	12	7,5	M5	M6	5,1	10	38	7	45	52
50	12	62	27,5	10	66	G1/8	6	29,7	16	7,5	M6	M8	6,7	13	46,5	8	45	53
63	12	73	27,5	10	78	G1/8	6	35,4	16	7,5	M6	M8	6,7	13	56,5	8	49	57
80	14	91	28,5	12	96	G1/8	8	46	20	8,5	M8	M10	8,5	16	72	10	54	64
100	16	111	28,5	12	115	G1/8	10	56,6	25	10	M10	M10	8,5	21	89	10	67	77

SPARE PARTS KITS CODE	
Ø (mm)	1 + 2 + 3 ⁽¹⁾
20	97802870
25	97802871
32	97802872
40	97802873
50	97802874
63	97802875
80	97802876
100	97802877

⁽¹⁾ For best results, use grease supplied in each kit. Supplementary tube (11 cm³) available on request, catalogue number: 97802100

DIRECT MOUNTING OPTIONS

The threaded mounting holes and the four unthreaded through holes (ØRR) ensure compatibility with a wide choice of screws and other fasteners recommended for short-stroke cylinders.

• Front mounting

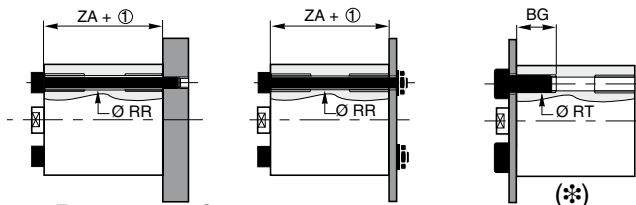

• Rear mounting

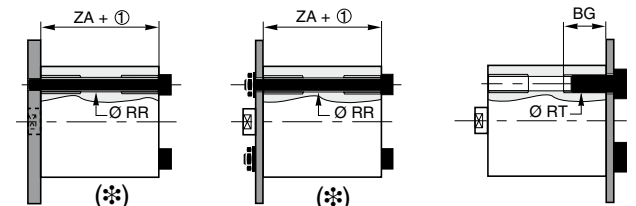

(*) Type of mounting not suitable with anti-rotation device