



RHE21

Exd / Exd(e) Extreme Environment Multifunction Coriolis Flow Transmitter

Features

- Wall or Pipe Bracket Mounting
- Corrosion resistant housing in SS316 available
- Selectable Units for Mass, Volume, Density and Temperature
- Positive, negative and net totalizers for both volume and mass flow
- Two configurable pulse/frequency outputs – double pulse available
- Two analog outputs
- Two configurable digital status outputs
- Configurable digital input
- Analog input configurable for pressure or density
- Advanced functions: Net Oil, Baume/Brix, % Solids, Standard Density and Standard Volume (API MPMS Ch. 11)
- Modbus RTU and HART
- Custody transfer lockout switch and seal point
- Back Lit Color LCD display and 3 behind-glass buttons with intuitive menu design
- Service & settings via PC running Rheonik **RHECom** software

- Built-in **Assurance View**® Advanced Diagnostic Set – clear publication of measurement status with **Assurance Factor**® and/or color changing display
- Password Protected Setup
- Upload and download of configuration files
- Power consumption less than 5 W

Applications

- General and critical process flows
- Feed stocks and transfers
- Custody transfer
- Well head production
- Offshore

Benefits

- More insight into process and measurement conditions with **Assurance View**®
- **Assurance Factor**® for proactive maintenance
- Works with all sizes of Rheonik RHM flow sensors
- Non-corrosive enclosure for extreme environments
- Fast and easy setup using **RHECom** software

RHE21 General Specifications

Housing:	Stainless steel. Optionally all 316 stainless steel
Enclosure Rating:	IP66 / NEMA 7X. Optionally IP67
Ambient Temperature:	-40 to +60°C / -40 to +140°F (reduced visibility below -20°C / -4°F)
Dimensions:	Depending upon construction type, please see Dimensions page (approx. 255 x 200 x 100 mm / 10 x 8 x 4 in)
Display:	Backlit color LCD. Screen changes color to indicate warning or error
Weight:	8 kg (17.5 lb)
Operation:	3 x behind-window capacitive sensors for menu navigation / settings
Sensor Connection:	Integral sensor cable with 3m or 10m length or optional IS terminal box for separate custom length sensor cable connection
Analog Outputs:	Up to 2 x 4-20mA outputs, active or passive, compl. to NAMUR NE-43
Digital Outputs:	Up to 2 x configurable status outputs (IEC60946)
Pulse/Frequency Outputs:	Up to 2 x configurable pulse/frequ. outputs (IEC60946), max 10 kHz
Digital Inputs:	Up to 2 x configurable control inputs (IEC60946)
Analog Input (optional):	1 x 4 - 20 mA analog input (active) for two-wire external sensor
Power Supply:	100-240 VAC +/- 10% (48 to 62 Hz), 5W or 12-24 VDC +/- 10%, 4W
Digital Data Communications:	Modbus RTU (RS485) Connection to a PC (USB) with Rheonik RHECom software HART over analog output
Cable Entries for I/O and Power Supply:	2 x M16 gland Ex e or 2 x ½" NPT entry Ex d Optional entries: ¾" NPT, M20 x 1.5, M25 x 1.5
Hazardous Area Approvals:	For ATEX/IEC Ex and CSA please see Part Number Code page Others available on request

Hazardous Area Installation Overview



Program Packages and Features

Standard Package (Part Number Code SO)

The RHE2x Standard programming package provides the following measurement and function features:

Direct Mass Flow Measurement

Mass flow is calculated using the Coriolis principle to provide a high accuracy Mass Flow measurement of the fluid flowing through an Omega Tube Coriolis meter.

Temperature Measurement

Each Omega Tube Coriolis Sensor provides a temperature measurement from built in sensors.

Fixed Density Function

The Fixed Density function allows density to be generated based upon process temperature. A base/reference density at a known temperature is entered for the fluid being measured along with a coefficient describing the change in density per temperature unit. The firmware in the transmitter calculates flowing density based upon this information to use for volumetric flow calculations.

Calculated Actual Volume Measurement for Liquids and Gas

Volume measurement is calculated by dividing direct mass flow measurement by the Fixed Density.

Standardized/Normalized Volume Measurement for Gas

This function calculates the volume of gas passing through the meter at standard conditions. The density of the gas at standard conditions is entered into the transmitter and the volume is calculated using this in conjunction with the flowing mass.

Password Protection

All setup and calibration parameters within the meter are protected with passwords to prevent unintentional or unauthorized change once installed.

Batch Controller

The transmitter is equipped with an onboard batch controller that, in conjunction with external pumps and/or valves allows the precise delivery of a preset mass or volume of process fluid on demand. Operated from the instrument front panel or remotely via operator switches, the controller is configured to utilize either a one stage or a two stage delivery strategy in ensuring the right amount of fluid is batched through the meter. The electronics self-learns, adjusting shut off times as more and more batches are delivered to further refine the amount of delivery, saving material costs and improving quality.

Program Packages and Features

Multifunction Package (Part Number Code DO)

The RHE2x Multifunction programming package includes all features from the Standard programming package plus the following measurement and function features:

Direct Density and Volume Measurement

The flowing density of the fluid in an Omega Tube Coriolis Sensor is determined from the measured resonant frequency of the sensor and used to calculate instantaneous volumetric flowrate.

Brix/Baume Units

The unit can be configured to read out in °Brix or Baume. °Brix or Baume are used extensively in the sugar and beverage industries.

Multifunction Package with Assurance Diagnostics Suite (Part Number Code AF)



The RHE2x Multifunction Package with Assurance Diagnostics Suite includes everything from the Multifunction package plus the following advanced diagnostic functions:

Assurance View® Diagnostics

Inbuilt self-monitoring functions are available that can be used to determine the reliability of the flow meter readings at all times. Diagnostics are quickly accessed through dedicated menu displays, RHECom software and the MODBUS interface.

Assurance Factor®

Assurance Factor® is a numeric value generated by an internal algorithm that indicates the overall health of the flow meter and measurement. **Assurance Factor®** value can be used to trigger changes in screen color (White – Amber – Blue – Red), providing highly visible wide area condition indication.

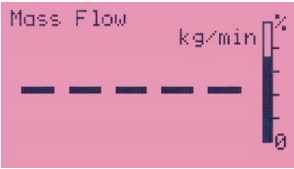
<h1 style="text-align: center; color: green;">ASSURANCE FACTOR®</h1>			
			
WHITE Normal Operation <i>No faults present. All parameters within expected limits. Meter fully operational</i>	AMBER Operation Not Optimal <i>Sensor subject to noise / changing conditions in pipe. Measurement quality may be compromised</i>	BLUE Operation at Limit <i>Sensor experiencing disturbance. Measurement quality compromised</i>	RED Measurement Failure <i>Sensor experiencing extreme disturbance / meter in fault. Measurement offline</i>

Program Packages and Features

Advanced Package (Part Number Code GV)

In addition to all Multifunction functions and the complete Assurance Diagnostics suite, the RHE2x Advanced package includes the following functions:

Standard Volume Calculations to API Standards for Liquid

This function calculates the volume of fluid passing through the meter at prescribed standard conditions according to API MPMS Chapter 11.

%Solids Measurement

The transmitter can be configured to generate a %Solids measurement based upon density. Standard flow and density functions are still available while %solids measurement is implemented.

Net Oil Function

The Net Oil Function Set provides full-stream real-time measurements of water cut, net oil volume flow and net water volume flow. Depending upon meter size, the flow meter can measure well production at rates from a few barrels per day to over 200,000 barrels per day. The net oil calculations are based upon Chapter 11 of the *American Petroleum Institute (API) Manual of Petroleum Measurement Standards*.

Power Supply Options

The RHE21 can be configured with one of three power supply options:

- **Universal AC Power - 100-240 VAC \pm 10% (48 to 62 Hz) (Part Number Code A1)**
- **Wide Tolerance DC Power - 12-24 VDC \pm 10%, 4W (Part Number Code D1)**
- **Dual Supply - 100-240 VAC \pm 10% (48 to 62 Hz) / 12-24 VDC \pm 10%, 4W (Part Number Code U1)**
This unique option provides inputs for simultaneous connection of both a universal AC and separate DC supply. The transmitter utilizes AC power when available but will switch to the DC supply in the event of AC power outage. The DC supply can be a battery source. As an example, an RHE27 transmitter and connected sensor will operate for 10 days or more on a typical automobile battery.

RHECom Software

The transmitter is a fully featured device with many sophisticated functions. Careful configuration is necessary if these functions are to perform as desired. License-free RHECom is available for download or on USB drive.



RHECom software is designed to ensure simple and expedient setup of the transmitter features and functions. The program operates on Windows™ based computers and has an intuitive user interface. Connection is via a standard USB port or the native RS485 connection of the transmitter. Communication between RHECom software and the transmitter uses MODBUS protocol.

MODBUS protocol may also be used by other systems to configure the transmitter and/or read measurement results through the native RS485 port. A full and detailed MODBUS register listing is available for designers when connecting the transmitter to supervisory control systems.

RHE21 Dimensions Type E1, E2

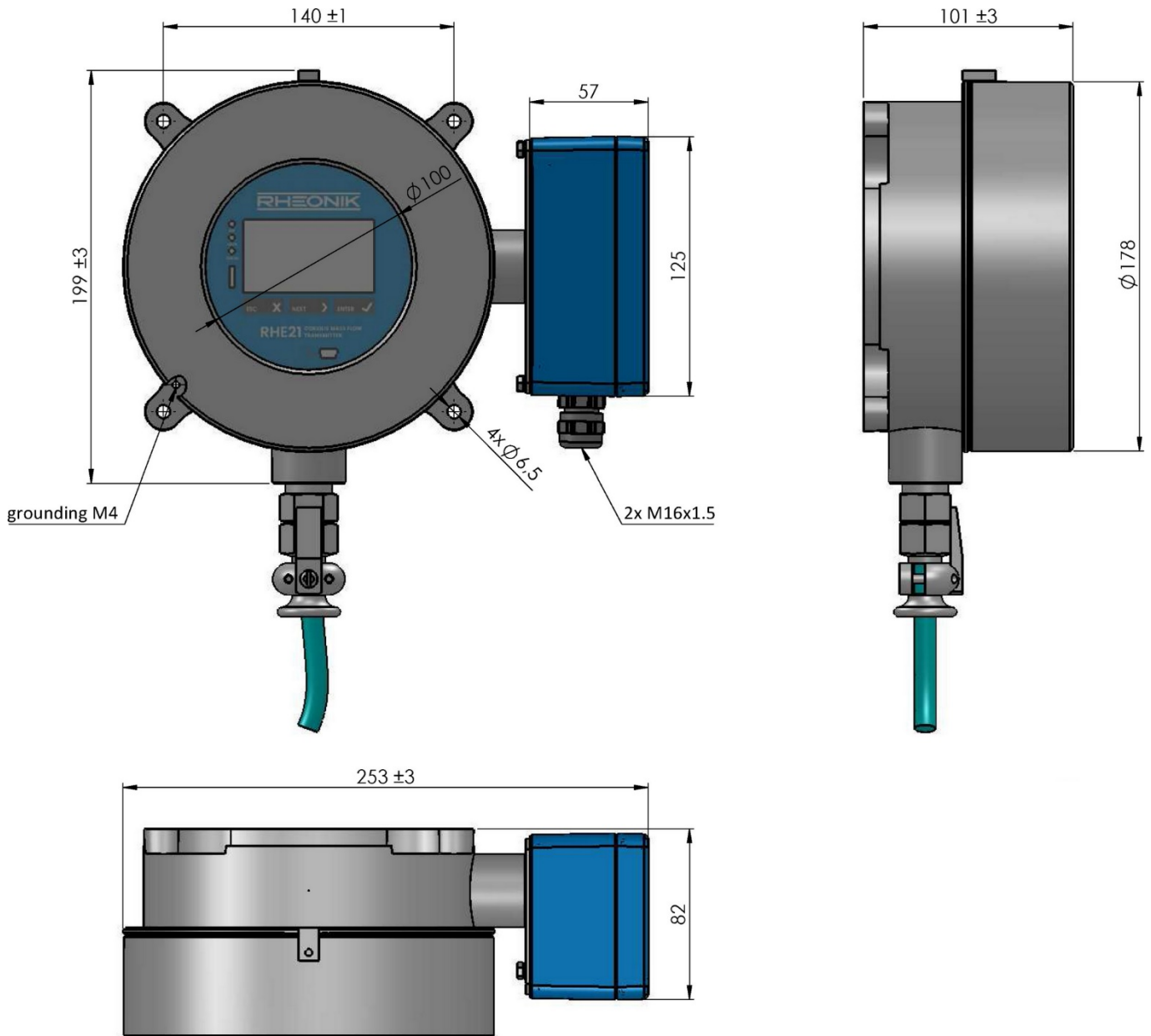

All dimensions in mm

RHE21 Dimensions Type E3, E4

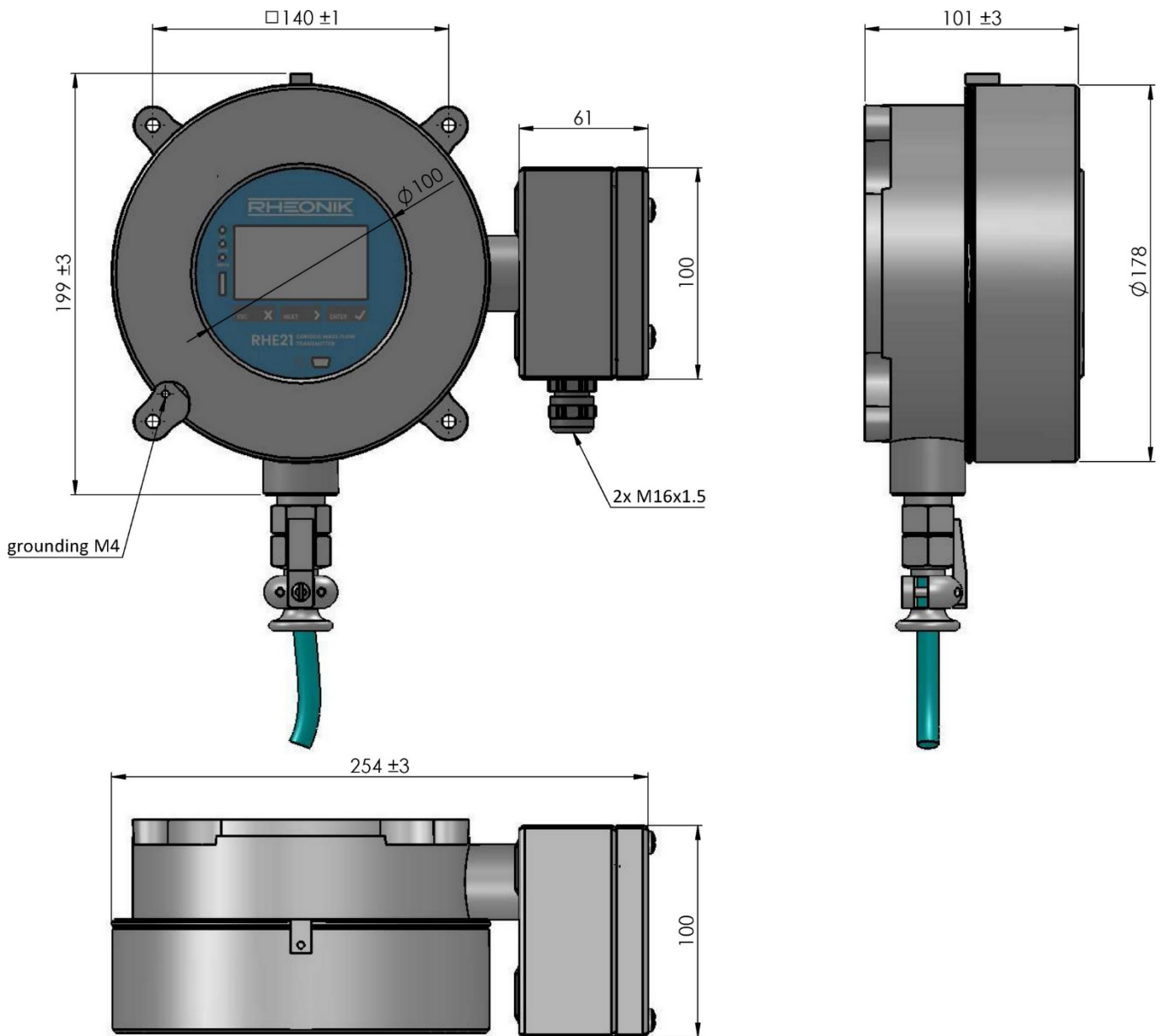

All dimensions in mm

RHE21 Dimensions Type E5

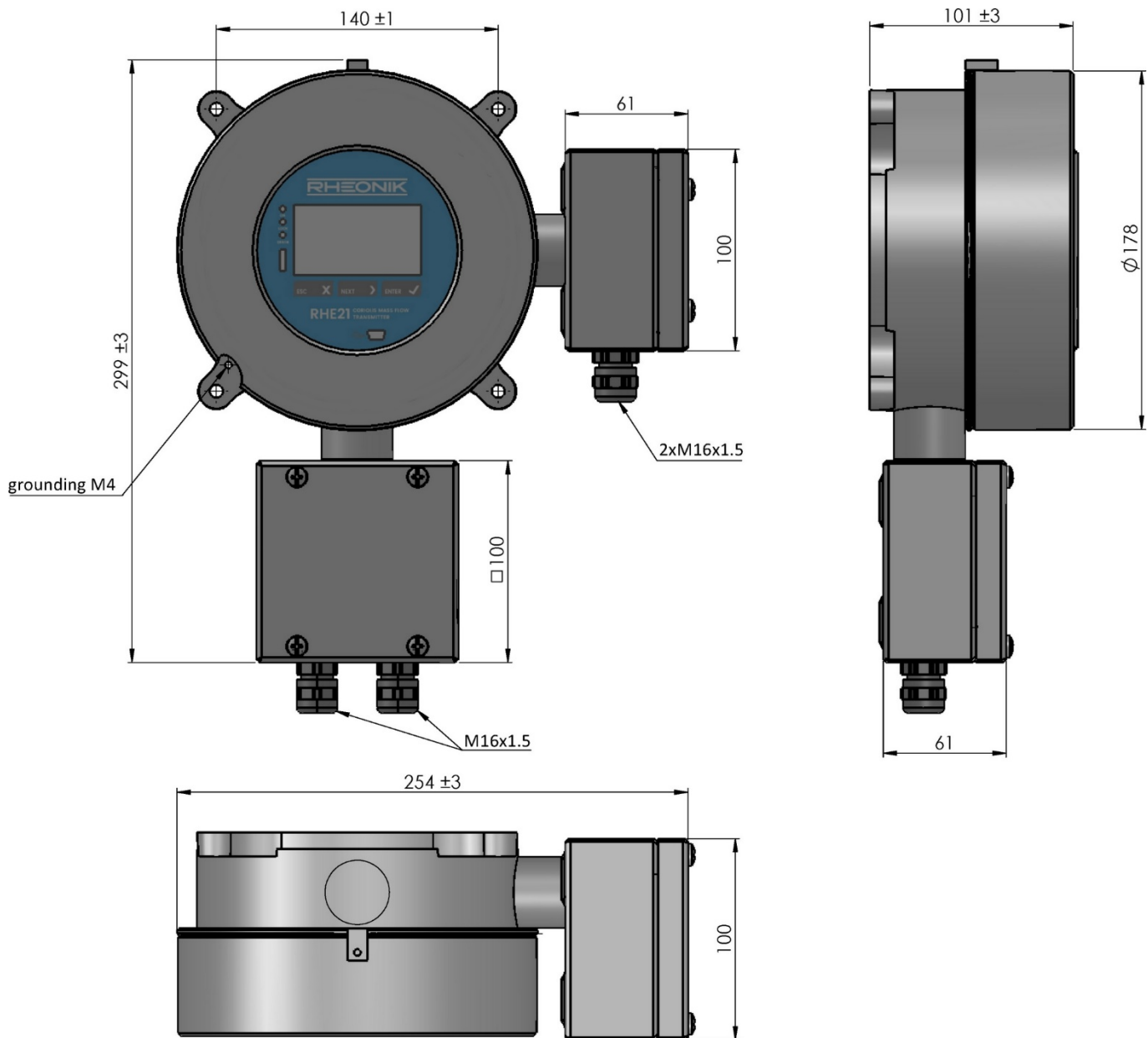

All dimensions in mm

Bottom sensor connection box has 1 x M16 gland standard, 2 x M16 gland only with analog input option

RHE21 Dimensions Type EP

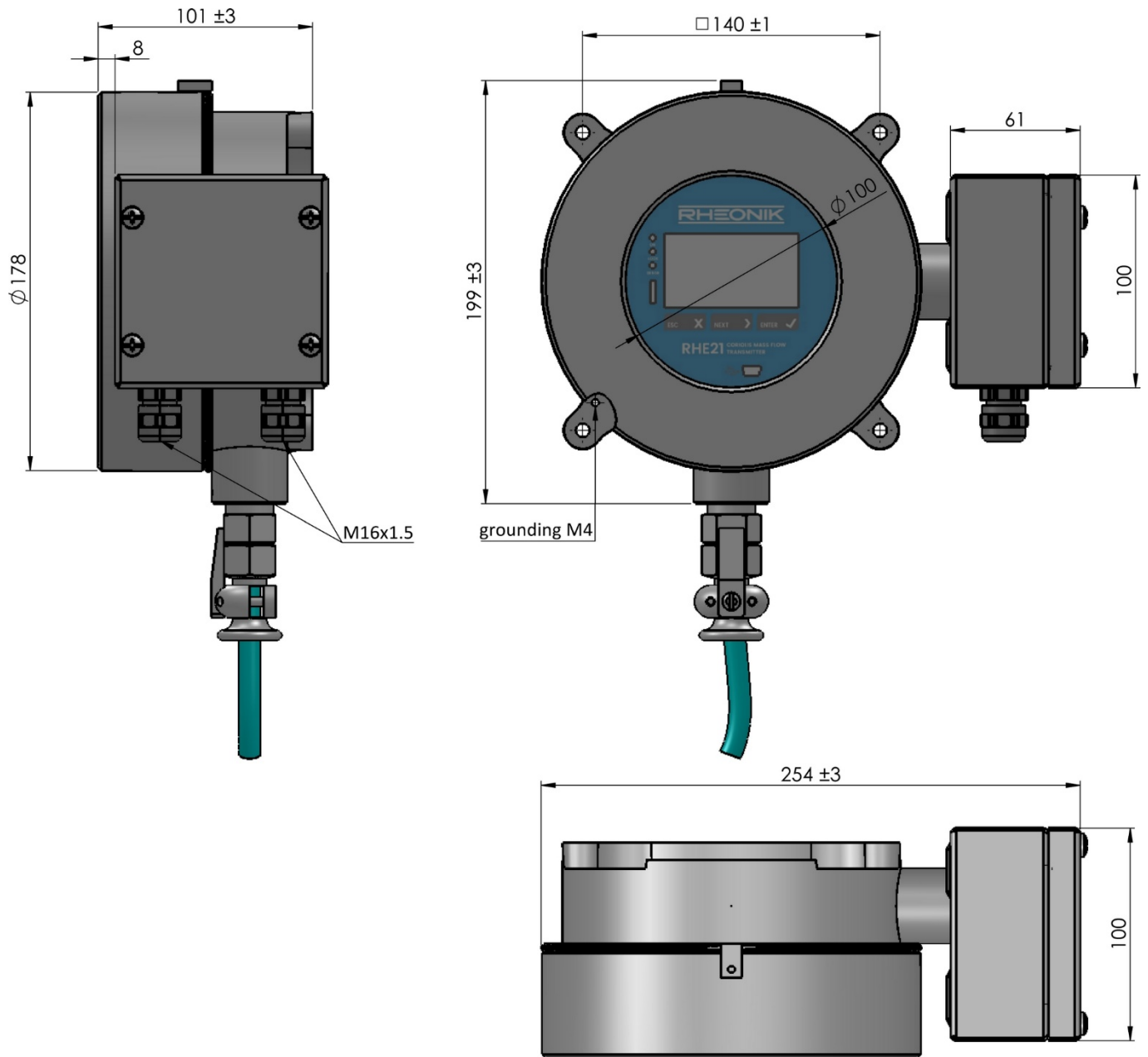

All dimensions in mm

Type EP for panel mount: 8 mm recessed I/O terminal box to fit RHE21 display front into panel window

RHE21 Dimensions Type H1, H2

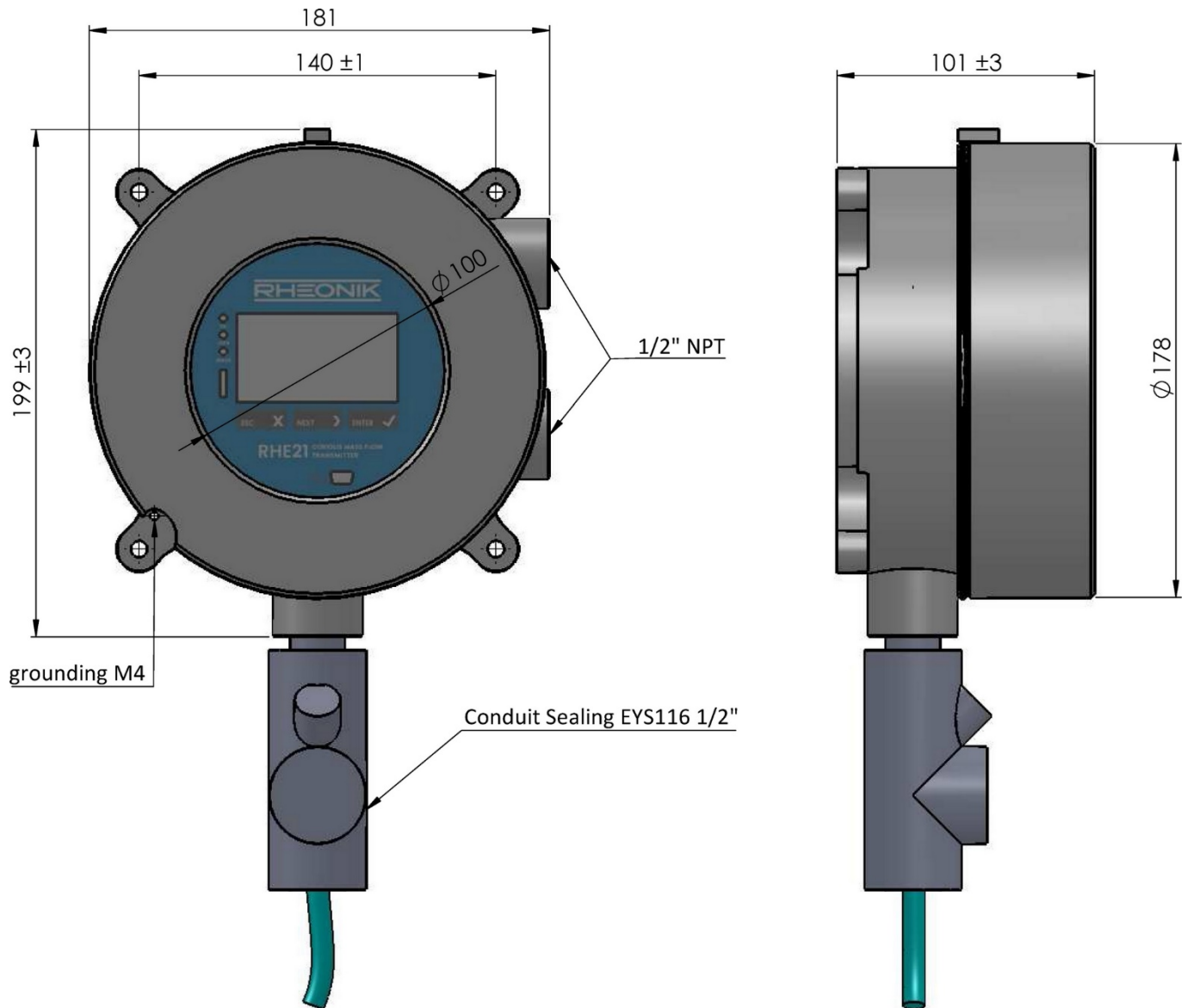

All dimensions in mm

Drawing shows CSA version. ATEX/IECEx version has the same sensor connection part as Type E1, E2, E3, E4

RHE21 Dimensions Type H3

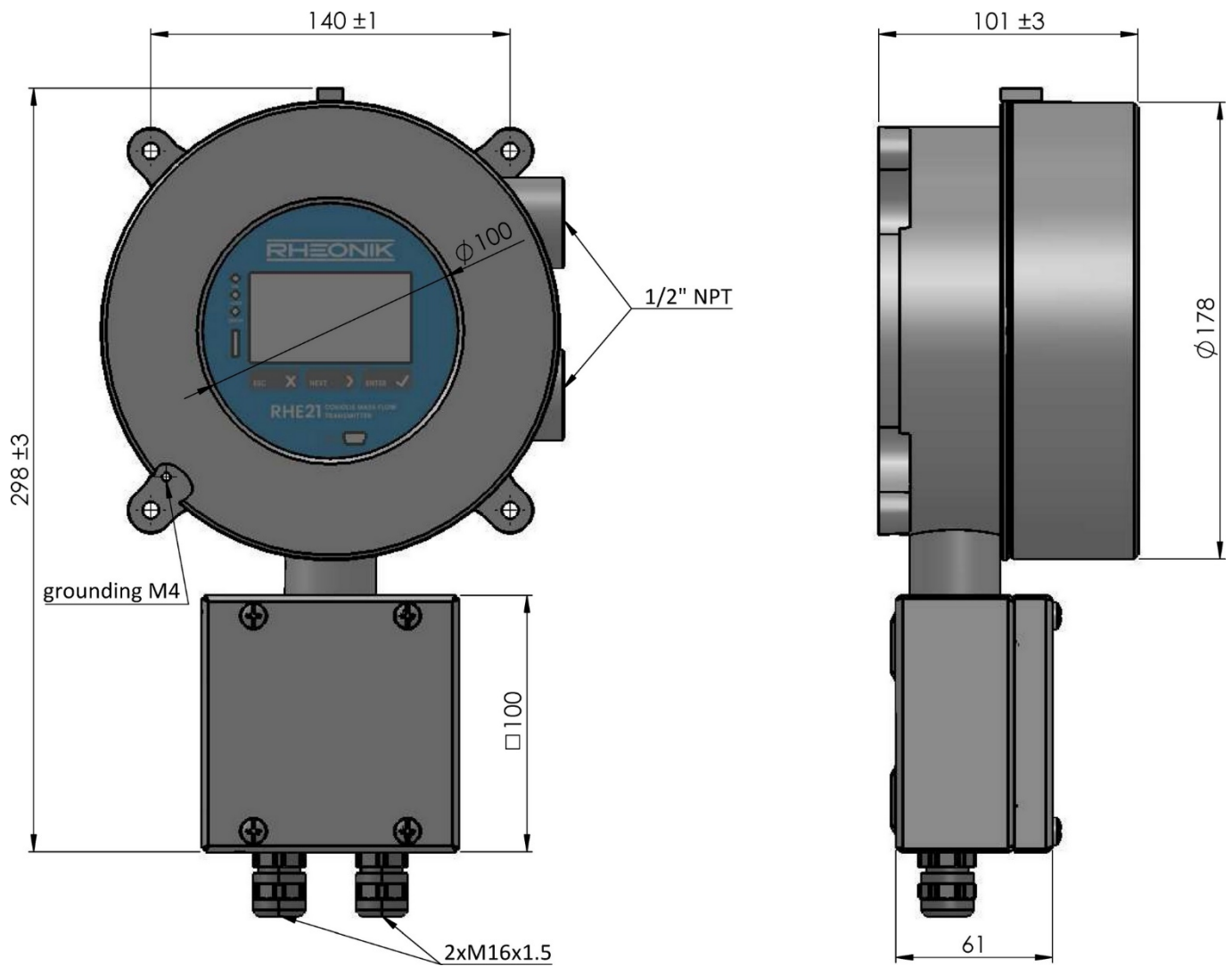

All dimensions in mm

Bottom sensor connection box with 1 x M16 gland standard. 2 x M16 gland only with analog input option

RHE21 Part Number Code

Construction Type

- E1** Stainless steel enclosure Exd(e), wall/hook, 1* Alu TB with 2* M16 gland Ex e, 3m sensor cable
- E2** Stainless steel enclosure Exd(e), wall/hook, 1* Alu TB w/ 2* M16 gland Ex e, 10m sensor cable
- E3** SS316 enclosure Exd(e), wall/hook, 1* SS316 TB with 2* M16 gland Ex e, 3m sensor cable
- E4** SS316 enclosure Exd(e), wall/hook, 1* SS316 TB with 2* M16 gland Ex e, 10m sensor cable
- EP** SS316 enclosure Exd(e), panel mount, 1* SS316 TB with 2* M16 gland Ex e, 10m sensor cable
- E5** SS316 enclosure Exd(e), wall/hook, 2* SS316 TB with 2* M16 gland Ex e, 2* M16
- H1** Stainless steel enclosure Exd, wall/hook, 2* cable entry 1/2" NPT, 3m sensor cable
- H2** Stainless steel enclosure Exd, wall/hook, 2* cable entry 1/2" NPT, 10m sensor cable
- H3** SS316 enclosure Exd, wall/hook, 2* cable entry 1/2" NPT, 1* SS316 TB with 2* M16

Supply Voltage

- D1** 12 to 24 VDC (+/- 10%)
- A1** 100 to 240 VAC (+/- 10%, 48 to 62 Hz)
- U1** 12 to 24 VDC (+/- 10%) and/or 100 to 240 VAC (+/- 10%, 48 to 62 Hz) - only Type H* (for E* cslt. factory)

Software Function Pack

- SO** Standard OP system - mass flow measurement incl. norm. density/volume
- DO** Enhanced OP system - mass, volume flow and incl. measured density/volume
- AF** Enhanced OP system plus Assurance Factor® Function (AF)
- GV** Enhanced OP system plus AF and API std. Vol. and Net Oil (add CH for all functions)
- CT** Enhanced OP system as GV plus hardware lock switch function

I/O Configuration

- S1** Standard One - 1*4/20mA (active), 2*DO (Pulse/Freq/Status), 1*DI, RS485 (Modbus)
- S2** Standard Two - 2*4/20mA (active), 1*DO (Pulse/Freq/Status), 1*DI, RS485 (Modbus)
- P1** Standard One - 1*4/20mA (passive), 2*DO (Pulse/Freq/Status), 1*DI, RS485 (Modbus)
- P2** Standard Two - 2*4/20mA (passive), 1*DO (Pulse/Freq/Status), 1*DI, RS485 (Modbus)
- SH** HART - as Standard Two S2 plus HART
- PH** HART - as Standard Two P2 plus HART
- CH** Premium - as Standard Two P2 plus HART and analogue input. Only with type E5, H3
- XX** Customized outputs are possible, please cslt. factory

Hazardous Area Approval

- NN** Without (sufficient to operate RHM in ATEX zone 2)
- AS** ATEX/IEC <Ex> (1)G [Ex ia Ga] IIC for RHM in zone 0,1 - RHE in ordinary area
- A2** ATEX/IEC <Ex> II 3(1)G Ex dc [ia Ga] IIC T4 Gc - RHE in zone 2
- A1** ATEX/IEC <Ex> II 2(1)G Ex db [ia Ga] IIC T4 Gb - RHE in zone 1
- CS** CSA US-Can. Class I, Div. 2 - RHM in Div. 1, 2 and RHE in ordinary area (only type H*)
- C2** CSA US-Can. Class I, Div. 2 - RHM in Div. 1, 2 and RHE in Div. 2 (only type H*)
- C1** CSA US-Can. Class I, Div. 2 - RHM and RHE in Div. 1, 2 (only type H*)

RHE21



Options for RHE 21

N67	Upgrade to IP67 rating
H-316	Set of two brackets for hook mounting in SS316
E1	1/2" NPT cable entries instead of M16 Ex e glands - only for SS316 I/O box
E2	M20 x 1.5 cable entries instead of M16 Ex e glands - only for SS316 I/O box
E3	3/4" NPT cable entries instead of M16 Ex e glands - only for SS316 I/O box
E4	M25 x 1.5 cable entries instead of M16 Ex e glands - only for SS316 I/O box
ARHE-MO	Modbus RS485 (screw terminals) to PC USB converter - to operate RHECom

Flow Sensor Range



Some of the many RHM mass flow sensors available

The RHM range of mass flow sensors features:

Line Sizes	From DN1 to DN300 / 1/24" to 12"
Pressure Ratings	Up to 1379 bar / 20000 psi
Temperature Ratings	From -200°C to 400°C / -328°C to 752°F
Wetted materials	Stainless Steel, Alloy C22, Duplex, Super Duplex, Tantalum, Others

RHE21 transmitters can be connected to all RHM Flow Sensors in the Rheonik Omega Tube range. Together they make a high performance measurement package suitable for many applications. For specific details on any sensor size, please see the relevant specification sheet.

About Rheonik

Rheonik has a single purpose: to design and manufacture the very best Coriolis meters available. Our research and engineering resources are dedicated to finding new and better ways to provide cost effective accurate mass flow solutions. Our manufacturing group care for each and every meter we produce from raw materials all the way to shipping and our service and support group are available to help you specify, integrate, start-up and maintain each and every Rheonik meter you have in service. Whether you own just one meter or have hundreds, you will never be just another customer to us, you are a valued business partner. Need a special configuration for your plant - don't compromise with a "standard" product from elsewhere. If we can't configure it from our extensive product range, we can build you what you need as a custom meter.

Rheonik only make Coriolis meters - we are **The Coriolis Experts** - contact us for all of your Coriolis meter requirements.